

PUBLIC ADDRESS / SPEAKERS / CEILING

GAT-601

100 V LINE TRANSFORMER CEILING SPEAKER

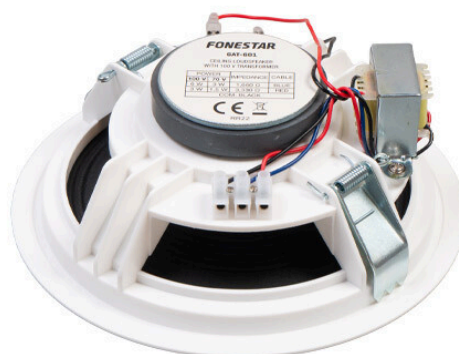
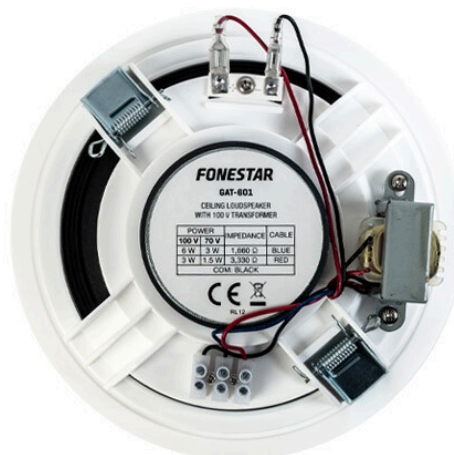
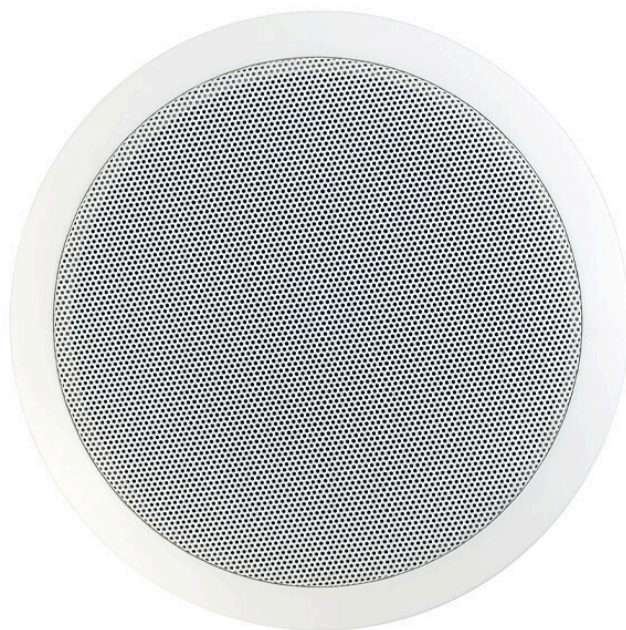

- ✓ Crisp and clean sound
- ✓ Quick installation system
- ✓ ABS built with fireproof case and aluminium grille



+ Info:
<https://fonestar.com/GAT-601>

ESPECIALLY RECOMMENDED IN:



Hospitality



Retail



Hotels



All sectors

DESCRIPTION

Pair of 6 ½" double cone ceiling speakers. 6/3/1.5 W RMS@100 V. Quick installation.

TECHNICAL CHARACTERISTICS

| | |
|--------------|--|
| FEATURES | Ceiling loudspeaker with 100 V line transformer and round aluminium grille. |
| POWER | 10 W maximum, 6 W RMS |
| LOUDSPEAKERS | 6 ½" double cone |
| RESPONSE | 140-20,000 Hz |
| IMPEDANCE | 6 W RMS@100V (1,660 Ohm) 3 W RMS@100V (3,330 Ohm) 1.5 W RMS@100V (6,660 Ohm) |
| SENSITIVITY | 92 dB ±3 dB at 1 W/1 m |
| MATERIAL | ABS and aluminium grille |
| COLOUR | White (RAL 9003) |
| DIMENSIONS | 188 mm Ø x 80 mm depth |
| HOLE | 168 mm Ø |
| WEIGHT | 0,63 kg |
| | Rapid installation system |



+ Info:
<https://fonestar.com/GAT-601>

SPL vs Frequency

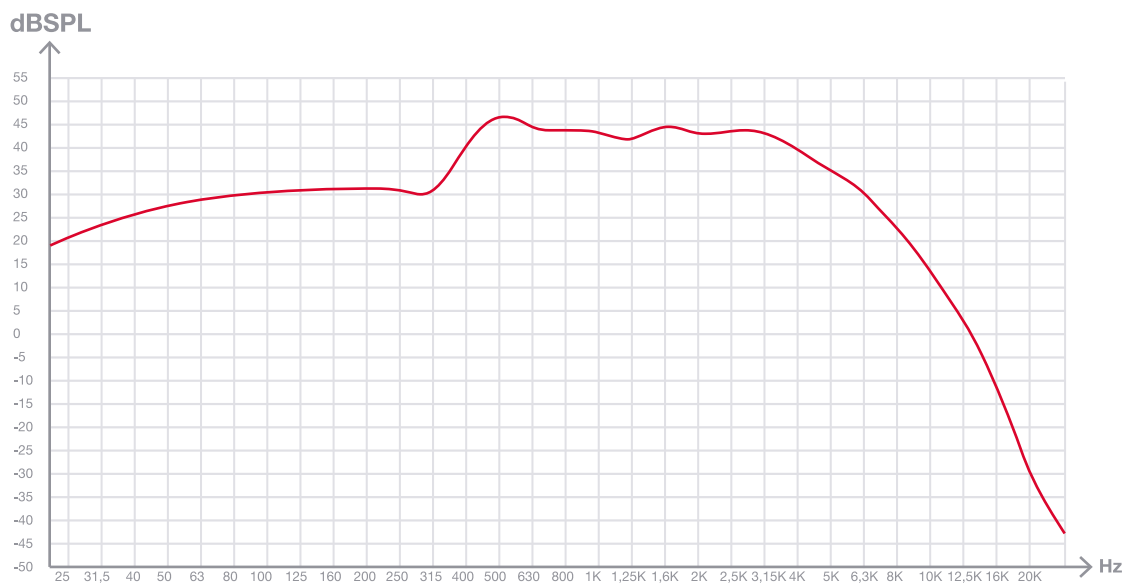

SPL vs Angle

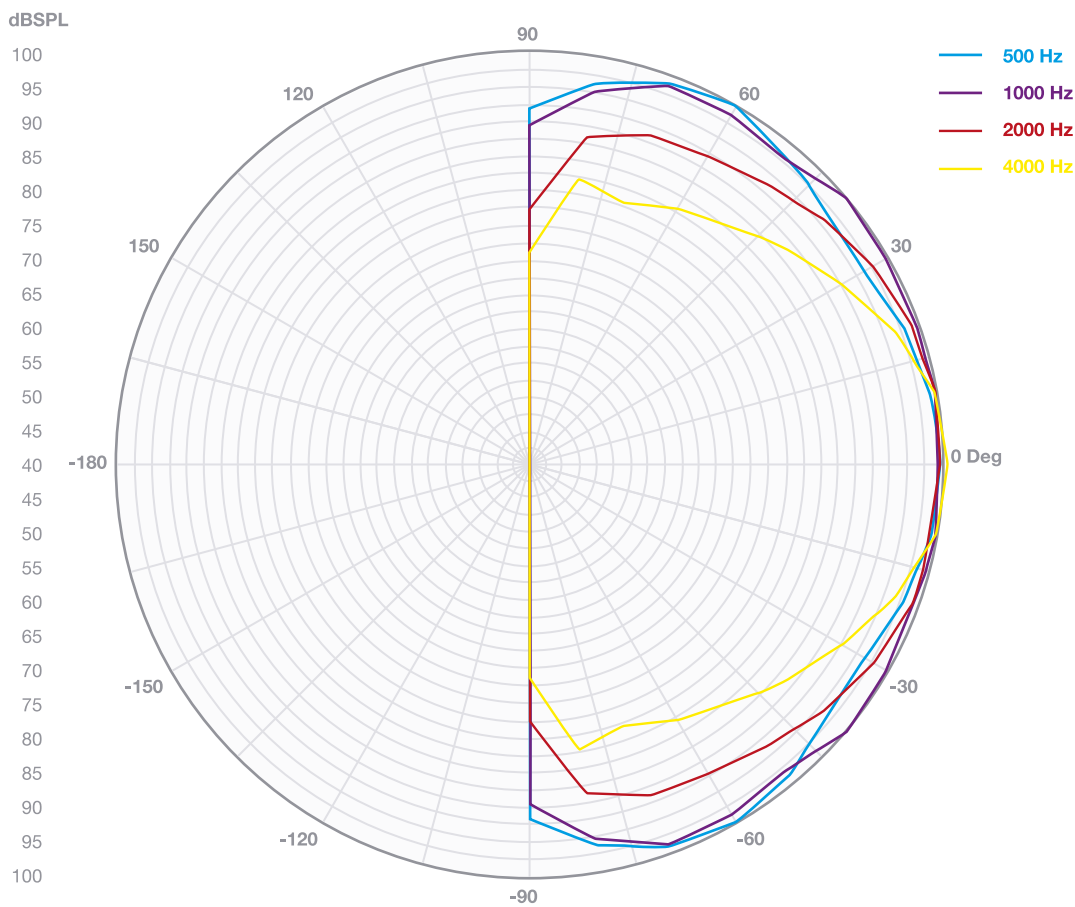

+ Info
<https://fonestar.com/GAT-601>

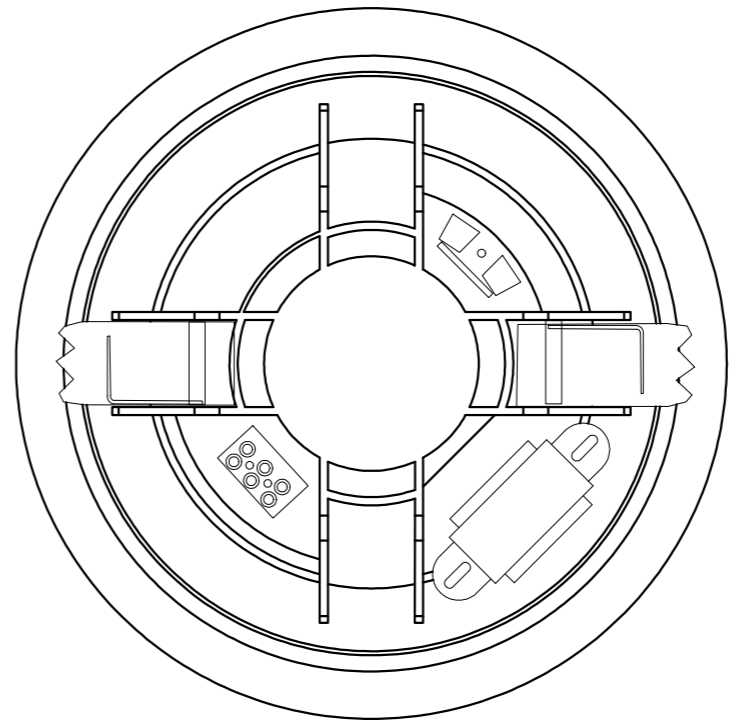
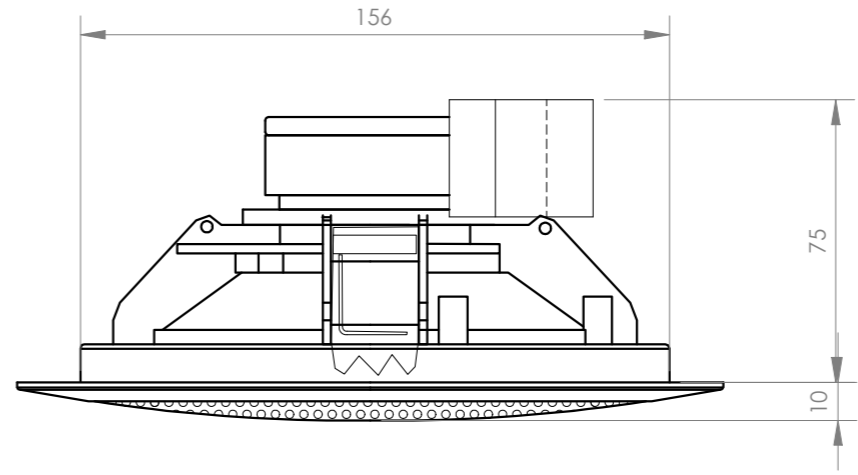
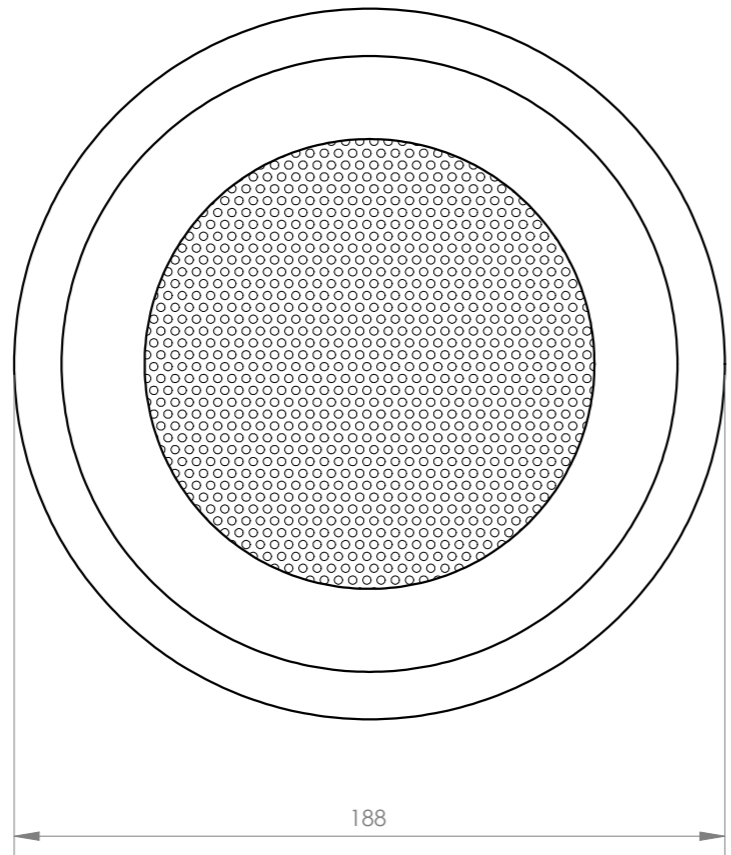

| | | | | |
|-----------------|---------|--|-------|-------|
| FONESTAR | Model | Description | Units | Scale |
| | GAT-601 | 100 V LINE TRANSFORMER CEILING SPEAKER | mm | 1:2 |